

Kobo Mini

User Guide

Table of Contents

About your Kobo eReader.....	5
Anatomy of your Kobo eReader.....	5
Charging your Kobo eReader.....	7
Charging your Kobo eReader with a wall adapter.....	8
Turning your Kobo eReader on and off.....	8
Using the touch screen.....	9
Connecting to your computer.....	10
Resetting your eReader.....	11
Using Wi Fi.....	13
Connecting your Kobo eReader to a Wi Fi network.....	13
Checking the Wi Fi status on your Kobo eReader.....	14
Turning Wi Fi off on your Kobo eReader.....	15
Syncing your Kobo eReader.....	16
Understanding Sync.....	16
Syncing your Kobo eReader with Wi Fi.....	17
Syncing your Kobo eReader with Kobo Desktop.....	17
Using your Library.....	19

Using your Home screen.....	19
Exploring your Library.....	20
Searching for books.....	21
Using the Kobo Cloud.....	23
About the Kobo Cloud.....	23
Downloading books from the Kobo Cloud to your Kobo eReader.....	24
Downloading all your books to your Kobo eReader at once. . .	25
Removing books from your Kobo eReader.....	25
Removing all books from your Kobo eReader.....	26
Reading on your Kobo eReader.....	28
Getting around a book.....	29
Changing text and font options on your Kobo eReader.....	30
Closing books.....	31
Bookmarking pages.....	32
Finding a bookmarked page.....	32
Highlighting text on your Kobo eReader.....	32
Seeing highlights on your Kobo eReader.....	33
Removing highlights on your Kobo eReader.....	34
Adding notes to your book on your Kobo eReader.....	34
Seeing your note while reading on your Kobo eReader.....	35
Removing notes from your books on your Kobo eReader	36

Using the dictionary on your Kobo eReader.....	37
Adding or removing dictionaries.....	37
Translating a word.....	38
Adding books.....	40
Browsing the Kobo Bookstore.....	40
Buying a book on your Kobo eReader.....	41
Adding a book to your Wishlist on your Kobo eReader.....	43
Viewing your Wishlist.....	43
Getting started with Adobe Digital Editions.....	44
Installing Adobe Digital Editions.....	45
Creating an Adobe ID.....	45
Authorizing your computer and your Kobo eReader with Adobe Digital Editions.....	46
Adding books to your eReader using Adobe Digital Editions.....	47
Getting Help.....	49
Getting Help.....	49
Safety, regulatory, and warranty information	49

About your Kobo eReader

What's in this section

- Anatomy of your Kobo eReader
- Charging your Kobo eReader
- Charging your Kobo eReader with a wall adapter
- Turning your Kobo eReader on and off
- Using the touch screen
- Connecting to your computer
- Resetting your eReader

Anatomy of your Kobo eReader

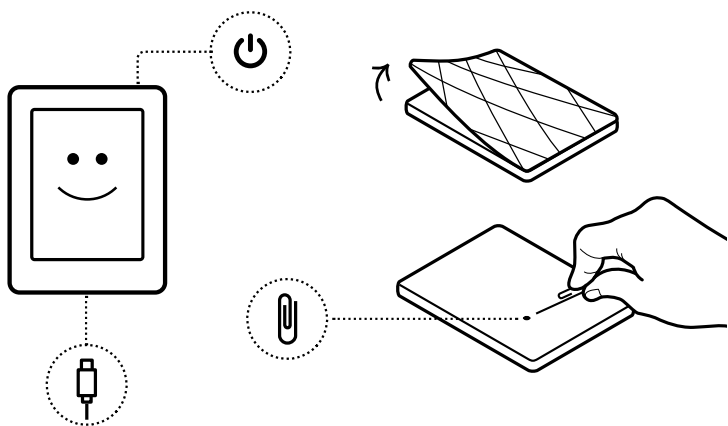

Power slider – Turn your eReader on or off, or put it to sleep.



Micro USB port – Connect your eReader to your computer using the supplied Micro USB cable to charge your eReader or add books.



Reset hole – Remove the back, insert a paper clip, and press gently to reset your eReader.

Charging your Kobo eReader

Before using your Kobo eReader for the first time, you should charge it for four hours. A fully charged Kobo eReader battery can last up to a month. We recommend you charge your Kobo eReader with the supplied Micro USB cable.

If you need to replace your Micro USB cable, you can get a new one at any location where Micro USB cables are sold. Follow these steps to charge your eReader.



1. Connect your Micro USB cable to your eReader and your computer.
2. If your eReader is on, tap **Cancel**.

You can continue reading while your eReader charges.

You can see the battery's charge in the top-right corner of the screen.

Battery icons

-  Out of power

-  Charging
-  Partially charged
-  Fully charged

Charging your Kobo eReader with a wall adapter

You can charge your Kobo eReader with any 5V, 500mA Micro USB adapter.

Note: If you're travelling to a country with different electrical systems, be sure you have the proper converter before you charge your Kobo eReader using a power outlet.

Turning your Kobo eReader on and off

Turning your Kobo eReader off or putting it to sleep both help your battery last longer.

When you put your eReader to sleep and then wake it up, you go directly back to the last screen you saw. This could be a page in a book, the Kobo Bookstore, or an area in your Library.

If you turn your eReader off, you'll go directly to your Home page when you turn it on again.

- **To turn your eReader on:** Slide the power button to the right and hold it for one second. The eReader will turn on and you will see the Powering On screen.
- **To put your eReader to sleep:** Slide the power button to the right and then release it quickly.
- **To wake up your eReader:** Slide the power button to the right and then release it.
- **To turn your eReader off:** Slide the power button to the right and hold it until the Powered off screen appears.

Using the touch screen

When your eReader is on, you can touch the screen to open books, turn pages, select items, and more. Here are a few gestures you might find useful.

- **Tap:** Touch the screen lightly to open a book, turn a page, select a menu, and more. This is the gesture you'll use the most.
- **Swipe:** Use this gesture to scroll through the books in your Library and turn pages.
- **Press and hold:** Touch the screen and hold your finger in place. This gesture lets you select text while reading. Press and hold a word, and when you let go, your eReader will underline your selection and show

a circle at each end of the word. Drag the circles to select more text.

Note: Not all books allow text selection. For example, you cannot select text in PDFs or comic books.

Connecting to your computer

Kobo Desktop is free software that lets you add and manage books on your eReader.

Kobo Desktop lets you:

- Quickly add and delete a large number of books on your eReader.
- Read books you've purchased from Kobo.
- Shop for books on your computer.
- Sync your eReader.

For more information about Kobo Desktop, you can:

- Download Kobo Desktop at kobosetup.com.
- Download the Kobo Desktop user guide from kobo.com/userguides.
- Search our help site at kobo.com/help.

Resetting your eReader

If your eReader isn't responsive or if you're experiencing problems with your eReader, you can try resetting it. If you reset your eReader, you'll need to sign in to your eReader and set it up again.

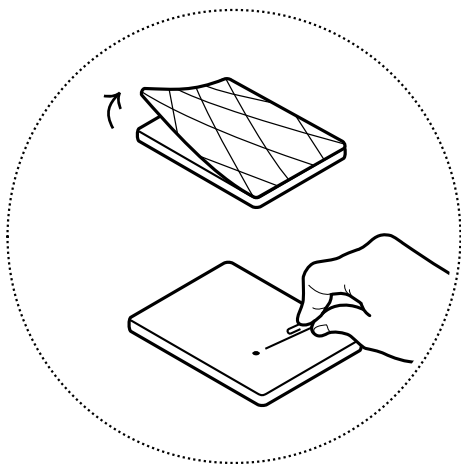

1. Remove the back of the eReader.
2. Insert a paperclip and press gently for a few seconds. Your eReader will restart.

-
-
3. Follow the onscreen instructions to set up your eReader.



Using Wi Fi

What's in this section

- Connecting your Kobo eReader to a Wi Fi network
- Checking the Wi Fi status on your Kobo eReader
- Turning Wi Fi off on your Kobo eReader

Connecting your Kobo eReader to a Wi Fi network

Use Wi Fi to connect to the Internet on your eReader. Wi Fi lets you find and buy books in the Kobo Bookstore, sync your Kobo eReader, and use the experimental browser. All you need is access to a wireless network.



1. Go to your Home screen.
2. Tap the  **Sync** tile.
Your eReader will try to connect to Wi Fi. This may take a moment.
3. You'll be prompted to choose a wireless network. Tap the name of the network you want to use. If there's a  Lock icon next to a network, you need a password to use that network.

4. If you're prompted for a network password, use the keyboard to type in the password and then tap **Join**. You can tap Show Password to see what you're typing.

Checking the Wi Fi status on your Kobo eReader

To see if you're connected to the Internet, check the Wi Fi status icon at the top of your screen.

Wi Fi icons

-  Wi Fi is disabled.
-  You have a moderately good Wi Fi connection.
-  You have an excellent Wi Fi connection.

You may have to sync your eReader to see the Wi Fi status icon.

1. Go to your Home screen.
2. Tap the  **Sync** tile. The Wi Fi status icon will appear at the top of the screen.

Turning Wi Fi off on your Kobo eReader

You can turn Wi Fi off to stop your Kobo eReader from connecting to the Internet. This will extend your eReader's battery life, and let you use your eReader on an airplane. Your Wi Fi connection will turn off automatically if it's inactive for more than five minutes.

1. Go to your Home screen.
2. Tap the  Menu icon at the top of the screen. The Quick Settings panel will appear.
3. Tap the checkbox beside **Wi Fi**.
When the checkbox is unselected, Wi Fi is turned off.

Syncing your Kobo eReader

What's in this section

- Understanding Sync
- Syncing your Kobo eReader with Wi Fi
- Syncing your Kobo eReader with Kobo Desktop

Understanding Sync

Syncing adds your purchases from the Kobo Store to your Kobo Library. If you read on another device, sync to update your place in your book, your annotations, and more. Syncing also updates Kobo eReader software to the latest version. Make sure your device is connected to Wi Fi before syncing.

There are two ways you can sync: using Wi Fi, or by connecting your Kobo eReader to Kobo Desktop on your computer.

Syncing your Kobo eReader with Wi Fi

Make sure your Wi Fi is enabled and you are connected to a network before syncing your eReader.



1. Go to your Home screen.
2. Tap the  **Sync** tile.
 - If you're within range of a known network, your eReader will automatically join that network and begin syncing.
 - If you aren't within range of a known network, your eReader will begin the Adding a Network process.

Syncing your Kobo eReader with Kobo Desktop

You can also sync your eReader by connecting it to your computer with Kobo Desktop. Kobo Desktop is free software that lets you add and manage books on your eReader. Your computer should be connected to the Internet before you sync.

To download Kobo Desktop, visit kobosetup.com.

1. Connect your eReader to your computer using your Micro USB cable.
2. Open Kobo Desktop on your computer.

3. If you're not already signed in to your Kobo account, click the  Profile icon at the top of your screen and sign in.
4. Click the  Sync icon.
5. Click the  Eject button at the top of the screen to disconnect your eReader from your computer.

Using your Library

What's in this section

- Using your Home screen
- Exploring your Library
- Searching for books

Using your Home screen

Your Home screen is the first thing you see when you turn on your eReader after setup. From your Home screen, you can see your recently opened books, access the Kobo Bookstore, and more.

Go to your Home screen by tapping the  Home icon at the top of the screen. While reading, tap the centre of your screen to see the Home icon.

Your Home screen is organized with tiles to make things easier to find. Tap a tile to interact with it.

Home screen tiles include:

- The book you're currently reading.
- Books you've recently opened or purchased.

- Recommended books we think you'll enjoy.
- The Sync tile to add newly purchased books to your Library and to update your eReader.

Above the tiles, you'll see the Search bar. Use the Search bar to find books in your Kobo Library or in the Kobo Bookstore.

At the bottom of your Home screen, you can access your Library, the Kobo Bookstore, and Extras, which include a dictionary and your personal reading statistics.

Exploring your Library

Your Library lets you read and manage books on your eReader.

To access your purchased books, free book previews, and collections in your Library:

1. Go to your Home screen.
2. Tap **Library**.
3. Select one of your Library areas:
 - **Books:** all the Kobo books, PDFs, and other documents in your Library.
 - **Previews:** excerpts of books you've added to your eReader as previews.

- **My collections:** books you've grouped together, much like bookshelves. For example, you can create a collection about cookbooks and only include culinary books.
- **Articles from Pocket:** online articles or webpages you've added using the free Pocket app on your computer, tablet, or other device.

Searching for books

Use the search bar at the top of your Home screen to find a book already in your Library, or a new book in the Kobo Bookstore.

Search using the book title, author name, or a keyword.

1. Go to your Home screen.
2. Tap the search bar at the top of the screen.
3. Choose where you'd like to search:
 - Select **Bookstore** to search the Kobo Bookstore (you must be connected to Wi Fi).
 - Select **Library** to search your eReader's library.
4. Using the keyboard, type a book title, author name, or keyword.
Search results will appear as you type.

5. Tap a suggestion to go to that result, or tap **Go** to see the full list of results.

Using the Kobo Cloud

What's in this section

- About the Kobo Cloud
- Downloading books from the Kobo Cloud to your Kobo eReader
- Downloading all your books to your Kobo eReader at once
- Removing books from your Kobo eReader
- Removing all books from your Kobo eReader

About the Kobo Cloud

All the books you purchase from Kobo are stored in the Kobo Cloud, an online storage area with unlimited space. You can choose which books you want to download from the Kobo Cloud to your device. When you finish a book, you can remove it from your device to increase storage space. You can re-download a book from the Kobo Cloud any time you have access to Wi Fi.

Downloading books from the Kobo Cloud to your Kobo eReader

If your books are stored in the Kobo Cloud, you'll need to download them to your eReader before you can read them. Make sure your eReader is connected to Wi Fi to download books from the Kobo Cloud.

1. Go to your Home screen.
2. Tap **Library**.
3. Tap **Books**.
Any books that aren't already downloaded onto your eReader will have a  Download icon on the cover.
4. Tap the book's cover to download it.
The book will begin downloading.
5. Tap the book's cover or title to open it.

If you select several books, your books will be placed in a queue and downloaded to your eReader one at a time. The word *Pending* will appear beside books that are in the download queue. Once a book is downloaded to your device, you don't need to be connected to Wi Fi to read it.

Downloading all your books to your Kobo eReader at once

You can download your entire library from Kobo onto your eReader.

1. Go to your Home screen.
2. Tap **Library**.
3. Tap **Books**.
4. Tap the  Tools icon at the bottom of the page.
5. Tap **Download all**.
6. If required, connect to a Wi Fi network.
The words *In Download Queue* will appear beside books that will be downloaded.

Removing books from your Kobo eReader

All the books you purchase from Kobo are stored in the Kobo Cloud, an online storage area with unlimited space. You can choose which books you want to download from the Kobo Cloud to your device. When you finish a book, you can remove it from your device to increase storage space. You can re-download a book from the Kobo Cloud any time you have access to Wi Fi.

1. Go to your Home screen.
2. Tap **Library**.
3. Tap **Books**.
4. Tap and hold the cover or title of the book.
A menu will appear.
5. Tap **Remove**.
A dialog box will appear.
6. Choose where you want to remove the book from:
 - eReader: This allows you to re-download the item from the Kobo Cloud later. This option is automatically selected.
 - Kobo account: This deletes the book from your Kobo account and all of your devices.
7. Tap **Remove**.

Removing all books from your Kobo eReader

You can remove all of your downloaded books from your eReader to free up storage space. When you remove books from your eReader, your books will be saved in the Kobo Cloud instead.

1. Go to your Home screen.

2. Tap **Library**.
3. Tap **Books**.
4. Tap the  Tools icon at the bottom of the screen.
5. Tap **More Settings**.
6. Beside *Downloaded Kobo books*, tap **Remove All**.
A dialog box will appear.
7. Tap **Remove**.
The content for all your books will be removed from your eReader.

Reading on your Kobo eReader

What's in this section

- Getting around a book
- Changing text and font options on your Kobo eReader
- Closing books
- Bookmarking pages
- Finding a bookmarked page
- Highlighting text on your Kobo eReader
- Seeing highlights on your Kobo eReader
- Removing highlights on your Kobo eReader
- Adding notes to your book on your Kobo eReader
- Seeing your note while reading on your Kobo eReader
- Removing notes from your books on your Kobo eReader
- Using the dictionary on your Kobo eReader
- Adding or removing dictionaries
- Translating a word





Getting around a book



You can quickly go to any chapter or page in your book with just a few taps.

Tap the cover or title of your book on your Home screen or Library to open it.

Tap or swipe the side of the page in your book to turn pages.

If you want to jump forward by more than a page or two:

1. Tap the centre of the page to bring up the Reading Menu.
2. Tap the  Navigation icon.
 - To scroll through the book's pages, touch the circle in the navigation bar and slide it to the right to move forward, or to the left to go back.
 - To move to the next page, tap the  Forward icon.
 - To move to the previous page, tap the  Back icon.
 - To jump to the next chapter, tap the  Jump Forward icon.

- To jump to the previous chapter, tap the  Jump Back icon.
 - To go to a chapter in the table of contents, tap **Table of contents** and tap the chapter.
 - Tap the  Snap Back icon to return to your previous position in the book.
3. Tap anywhere on the page to close the navigation bar.

Changing text and font options on your Kobo eReader

Your eReader offers several different sizes of text for most books. You can adjust the text size, fonts, line spacing, and justification to make reading easier on your eyes.

1. While reading, tap the middle of your page to bring up the Reading Menu.
2. Tap the  Text icon.
3. Adjust your font settings:
 - Tap the dropdown menu beside **Font Face** to select from a list of available fonts.
 - Drag the slider beside **Font Size** to change the size of the type.

- Drag the slider beside **Line Spacing** to increase or decrease the space between lines of type.
- Drag the slider beside **Margins** to make the side margins bigger or smaller.
- Tap your choice of **Justification**.

Notes:

- When you change the way text looks, your eReader remembers your preferred size and style, and applies it to other books you're reading.
- If you're reading a PDF, you can't change the size or style of the text.

Closing books

When you're done with a book, you can mark it as *Finished* so that the next time you open it, you'll start at the beginning.

Marking a book as *Finished* won't remove any bookmarks, annotations, or highlights.

1. In your Library, find the book you'd like to close.
2. Press and hold the book's cover.
A menu will appear.
3. Select **Mark as finished**.

Bookmarking pages

You can mark interesting passages or pages that you'd like to return to using bookmarks.

- While reading, tap the top-right corner of the page. A dog-ear will appear.

Finding a bookmarked page



If you added a dog-ear to a page, you can easily find it again using the Reading Menu.

1. While reading, tap the centre of the page to bring up the Reading Menu.
2. Tap the  Book icon at the bottom of the page.
3. Tap **Annotations**.
4. Tap the bookmark you want to see.

Highlighting text on your Kobo eReader

Most books let you highlight text, just like using a highlighter in a printed book.

Note: You cannot highlight text in a PDF.

1. While reading, press and hold a word for a few seconds until an underline appears.
2. Lift your finger from the page.
You'll see a  circle icon at each end of the word.
3. Drag the first circle to the start of the text you want to select, and the second circle to the end.
4. Tap the  Highlight icon.
5. Tap **Highlight**.

Seeing highlights on your Kobo eReader

You can see the list of highlights you made in the book while you're reading.

1. Tap the centre of the page.
The Reading Menu will appear.
2. Tap the  Book icon at the bottom of the page.
3. Tap **Annotations**.
A list of bookmarks, highlights, and notes that you made in your book will appear.
4. Tap on a highlight to see the entire highlighted passage.

Removing highlights on your Kobo eReader

You can remove highlights you made in your book while you're reading.

1. Tap the centre of the page.
The Reading Menu will appear.
2. Tap the  Book icon at the bottom of the page.
3. Tap **Annotations**.
A list of bookmarks, highlights, and notes that you made in your book will appear.
4. Tap the Menu icon beside the highlight you'd like to remove.
A menu will appear.
5. Tap **Remove highlight**.
The highlight will be removed from your book.

Adding notes to your book on your Kobo eReader

You can add notes to your books while you're reading.

1. While reading, press and hold a word for a few seconds, until an underline appears.

2. Lift your finger from the page.
You'll see a  circle icon at each end of the word.
3. Drag the first circle to the start of the text you want to select, and the second circle to the end.
4. Tap **Add Note**.
5. Use the keyboard to enter your notes, and tap **Save**.

Seeing your note while reading on your Kobo eReader

After you've made a note, you can see it any time while you're reading.

1. Tap the centre of the page.
The Reading Menu will appear.
2. Tap the  Book icon at the bottom of the page.
3. Tap **Annotations**.
A list of bookmarks, highlights, and notes that you made in your book will appear.
4. Tap on the text beside *Note* on the right to view your entire note.

Removing notes from your books on your Kobo eReader

If you no longer need a note, you can delete it from your book while you're reading.

1. Tap the centre of the page.
The Reading Menu will appear.
2. Tap the  Book icon at the bottom of the page.
3. Tap **Annotations**.
A list of bookmarks, highlights, and notes that you made in the book will appear.
4. Tap and hold the note that you'd like to delete.
A menu will appear.
5. Tap **Remove annotation**.
A dialog window will appear.
6. Tap **Continue** to delete your note.

Using the dictionary on your Kobo eReader

If you see an unfamiliar word while you're reading, you can use your eReader's built-in dictionary to view its definition.



1. While reading, press and hold the word you'd like to look up.
An underline will appear beneath the word.
2. Lift your finger from the page.
The word's definition will appear.

The dictionary may not work in some books such as PDFs, books you borrowed from a public library, or free books you found on the Internet.

Adding or removing dictionaries

You can remove the dictionaries that are installed on your eReader to save storage space, or add dictionaries in other languages.

1. Go to your Home screen.
2. Tap the  Menu icon at the top of the screen.
The Quick Settings panel will appear.
3. Tap **Settings**.

4. Tap **Language**.
5. Under Dictionary, tap **Edit**.
6. Add or remove a dictionary:
 - Tap the  plus icon beside the dictionary you want to add.
 - To remove a dictionary, tap the  check mark icon.
7. Tap **Save**.

Translating a word

Your Kobo eReader has a translation dictionary that you can use while reading Kobo eBooks.

The dictionary may not work in some books such as PDFs, books you borrowed from a public library, or free books you found on the Internet.

1. In your book, press and hold the word you'd like to translate.
2. Lift your finger from the screen.
A definition of the word will appear in a dialog box.
3. Tap the  dropdown icon at the bottom-right corner of the dialog box.

A list of languages will appear in the dropdown menu.

4. Select the language that you'd like to translate to.

Adding books

What's in this section

- Browsing the Kobo Bookstore
- Buying a book on your Kobo eReader
- Adding a book to your Wishlist on your Kobo eReader
- Viewing your Wishlist
- Getting started with Adobe Digital Editions
- Installing Adobe Digital Editions
- Creating an Adobe ID
- Authorizing your computer and your Kobo eReader with Adobe Digital Editions
- Adding books to your eReader using Adobe Digital Editions

Browsing the Kobo Bookstore

You can find and buy books in several ways on your eReader.

1. Go to the Home screen.
2. Tap **Bookstore**.

3. Tap any of the listed options:
 - **Storefront:** See Kobo's latest releases. You can also access the search bar through Storefront, to find a book by title, author, or keyword.
 - **Related reading:** Books similar to those you're reading or looking up in the Kobo Store.
 - **Recommended for you:** Books Kobo thinks you might enjoy, based on your purchases and reading history.
 - **Categories:** A list of topics that can help you find books. Select a subject that interests you.
 - **Reading lists:** Books organized thematically for easy browsing.
 - **Wishlist:** Where you can save books you'd like to read later.

Buying a book on your Kobo eReader

You can buy eBooks right on your eReader. All you'll need is a Wi Fi connection and a valid credit card.

Once you've completed the checkout process, your book will appear on the Home screen.

1. Go to your Home screen.
2. Tap **Bookstore**.

3. Find an eBook you'd like to buy.
4. Tap **Buy** next to the book you want to purchase.
5. If you've shopped with Kobo before and saved your billing information, go to step 9.
6. Use the keyboard to enter your billing address and credit card information.
Note: We need your billing address to calculate taxes for your order based on your location.
7. Tap **Done** to continue.
8. Review your order.
9. If you want to use a gift card or promo code, tap **Add Gift Card** or **Add Promo Code** and provide the needed information.
Note: Promo codes can only be applied to eligible books or magazines, since not all publishers choose to take part in promotions.
10. Tap **Buy Now**.
11. Tap **Keep Shopping** to buy more books, or return to the Home screen.
Note: If you don't see the book you purchased on the Home screen, tap the  **Sync** tile.

Adding a book to your Wishlist on your Kobo eReader

With Wishlist, you can keep track of books that you're interested in buying later.

1. While shopping for a book, tap the  Pin icon. A dialog box will appear to confirm that you've added your book.

Viewing your Wishlist

After you've added books to your Wishlist, you can see the Wishlist from your eReader.

1. Go to your Home screen.
2. Tap **Bookstore**.
3. Tap **Wishlist**.

You'll see a list of books that you added to your Wishlist. Tap on the book and follow the onscreen instructions to purchase it.

Getting started with Adobe Digital Editions

Adobe Digital Editions (ADE) is free software that lets you add eBooks from a public library, eBooks from another store, or eBooks from the Kobo Store that are protected by Digital Rights Management (DRM), to your Kobo eReader.

DRM prevents the unauthorized copying or redistribution of eBooks, to protect the rights of authors and publishers. If you downloaded a book protected by DRM, you'll get a license, also known as a URLINK.acsm file, with your book. You will use ADE to add DRM-protected content to your eReader.

To get started with ADE:

- Install Adobe Digital Editions
- Get an Adobe ID
- Authorize your computer and eReader with ADE

Note: If you use a Kobo eReader or Kobo's reading apps, you may never need to use ADE. Kobo's reading apps and eReaders can automatically download and open most books from the Kobo Store.

Installing Adobe Digital Editions

Install Adobe Digital Editions (ADE) on your PC or Mac computer to transfer Digital Rights Management (DRM)-protected content onto your Kobo eReader.

1. Download ADE from Adobe.com.
2. Find the ADE installation file on your computer.
3. Open the ADE installation file.
4. Follow the onscreen instructions.

Creating an Adobe ID

Once you've installed Adobe Digital Editions on your PC or Mac, you'll need to create an Adobe ID.

1. In your web browser, go to Adobe.com.
2. Click **Sign in**.
3. Click **Get an Adobe ID**.
4. Fill in the appropriate text boxes on the form.
5. Click **Sign up**.

Authorizing your computer and your Kobo eReader with Adobe Digital Editions

After you've installed Adobe Digital Editions (ADE) and created an Adobe ID, you'll need to authorize your computer and your eReader with ADE. You only need to do this once.

1. Launch ADE on your PC or Mac.
2. From the Help menu, click **Authorize Computer**. A Computer Authorization window will appear.
3. Enter your Adobe ID and password.
4. Click **Authorize**.
5. Click **OK** when Adobe finishes authorizing your computer.
6. Connect your eReader to your computer and tap **Connect**.
7. In ADE, right-click on **Kobo eReader** under Devices on the left.
8. Click **Authorize Device...**
9. Select the account that you'd like to authorize.
10. Click **Authorize Device**.

11. Click **OK** to complete the process.

Adding books to your eReader using Adobe Digital Editions

If you downloaded a book protected by Digital Rights Management (DRM), you'll get a license, also known as a URLINK.acsm file, with your book. To get the book itself, just open that file in Adobe Digital Editions (ADE). ADE will verify your license, and then download your eBook in either EPUB or PDF format.

1. Turn on your eReader.
2. Connect your eReader to your computer using a Micro USB cable.
3. Tap **Connect** on your eReader.
4. On your computer:
 - a. Go to the folder where your eBook is saved.
 - b. Double-click the URLINK.acsm file.
The book will open in ADE.
 - c. Click **Library** at the top of the screen.
 - d. Click **All Items** under the Bookshelves menu.

- e. Select your new book and drag it to the Kobo eReader bookshelf (listed on the left side under Devices).
5. Eject your eReader from the computer, and unplug the Micro USB cable from your eReader. The book will appear in your Library.

Getting Help

What's in this section

- Getting Help
- Safety, regulatory, and warranty information

Getting Help

Have questions or need help? Visit kobo.com/help.

Safety, regulatory, and warranty information

Important safety, regulatory, and warranty details about your eReader can be found at kobo.com/userguides.

Note: The Declaration of Conformity may vary for different models of the Kobo eReader. Kobo.com/userguides includes information about how to find your Kobo eReader's model number.